

# SAVEMA D-160



**Savema**

## Label applicators

The Savema D-160 label applicator provides the versatility and reliability to apply labels up to 160mm wide at speeds up to 45 m/min. It can function as a stand-alone applicator, or with the addition of a Savema TTO printer, it can function as a complete print and apply system.

---

### Standard features

- Servo Drive Motor
- 4.3" Touch-Screen controller
- Relay connection (NPN or PNP)
- Photocell connection (NPN or PNP)
- 45 m/min label speed

### Available features

- USB connection
  - Ethernet connection
  - Encoder
  - Blower mechanism
  - Transparent label sensor
-

## SAVEMA D-160

### Technical Specifications

SPECIFICATIONS	DISPENSER D-160
Label Speed	Max. 45 meters/min
Power Supply	100-240V AC, 500W, 50-60 Hz
I/O Interface	Label Feeding Signal Input / Fault Signal Output, Busy Signal Output
Interface (optional)	Modbus RTU, Modbus TCP, Ethernet TCP/IP, Can-Open, Start / Stop Signal
Connection Properties	Relay (NPN-PNP) – Photocell (NPN-PNP)
Advanced Properties	Working with encoder or without encoder, printer can be connected (optional) blower mechanism can be connected (optional), transparent label sensor (optional), missing label error, label broken error, printer fault error
Operation	4.3" / 272x480 pixel resolution touchscreen, user menu, setting menu, user start/stop, user administration, manual label feed
Language	Multi-Language System (TR, EN, IT, DE, RU, AR, FR, ES, CS, NL, CN, KO, PT, EL, FA)
Max Label Roll Diameter	300 mm
Reel Holder	76 mm
Max Label Width	160 mm
Weight	30 kg
Printers Can be Installed	SVM 32 Intermittent Printers SVM 53 Intermittent Printers

### SVM D-160 (HORIZONTAL)

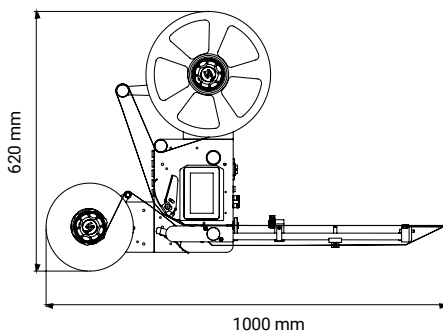
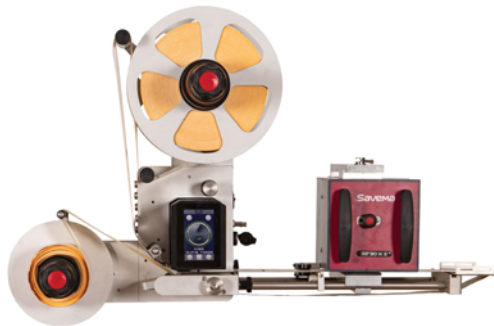

### SVM D-160 (VERTICAL)

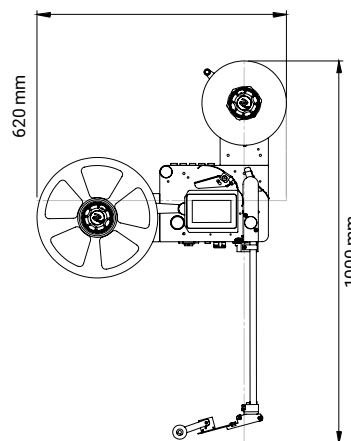

**Savema**

For more information, contact Tigerpak Industrial Supplies,  
6810 Kitimat Rd, Unit 1, Mississauga, Ontario, L5N 5M2, Canada.

Telephone:  
Ontario (289) 328-0651, (877) 538-8078  
Quebec (514) 587-2607, (855) 296-4372

E-mail: Sales@Tigerpak.ca Info@Tigerpak.ca  
Website: www.tigerpak.ca

