

# SAVEMA D-110



**Savema**

## Label applicators

The Savema D-110 label applicator provides the versatility and reliability to apply labels up to 110mm wide at speeds up to 30 m/min per minute in the standard version, or 60 m/min per minute in the high-speed version. It can function as a stand-alone applicator, or with the addition of a Savema TTO printer, it can function as a complete print and apply system.

---

### Standard features

- Servo Drive Motor
- 4.3" Touch-Screen controller
- Relay connection (NPN or PNP)
- Photocell connection (NPN or PNP)
- 30 m/min (S version) 60 m/min (F version)

### Available features

- USB connection
  - Ethernet connection
  - Encoder
  - Blower mechanism
  - Transparent label sensor
-

## SAVEMA D-110

### Technical Specifications

SPECIFICATIONS	D-110 S	D-110 F
Label Speed	Max. 30 meters/min	Max. 60 meters/min
Power Supply	100–240V AC, 500W, 50–60 Hz	
I/O Interface	Label Feeding Signal Input / Fault Signal Output, Busy Signal Output	
Interface (optional)	Modbus RTU, Modbus TCP, Ethernet TCP/IP, Can-Open, Start / Stop Signal	
Connection Properties	Relay (NPN-PNP) – Photocell (NPN-PNP)	
Advanced Properties	Working with encoder or without encoder, printer can be connected (optional) blower mechanism can be connected (optional), transparent label sensor (optional), missing label error, label broken error, printer fault error	
Operation	4.3" / 272x480 pixel resolution touchscreen, user menu, setting menu, user start/stop, user administration, manual label feed	
Language	Multi-Language System (TR, EN, IT, DE, RU, AR, FR, ES, CS, NL, CN, KO, PT, EL, FA)	
Max Label Roll Diameter	300 mm	
Reel Holder	76 mm	
Max Label Width	110 mm	
Weight	25 kg	
Printers Can be Installed	SVM 32 Intermittent Printers	
	SVM 53 Intermittent Printers	

### SVM D-110 (HORIZONTAL)

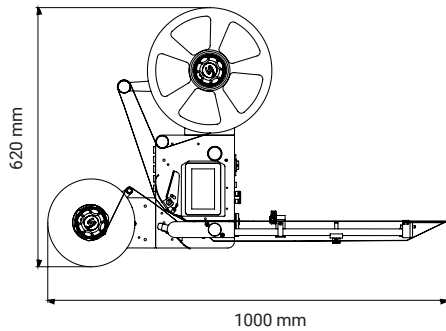
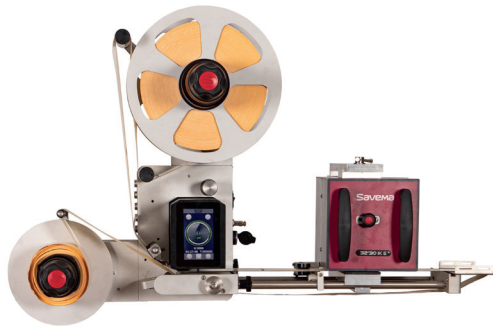

### SVM D-110 (VERTICAL)

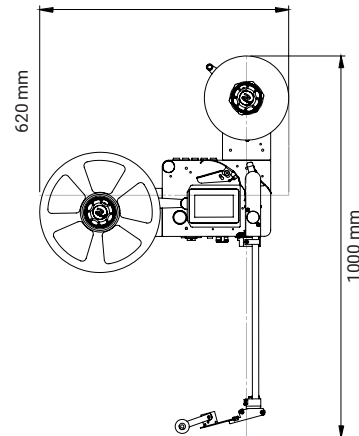

**Savema**

For more information, contact Tigerpak Industrial Supplies,  
6810 Kitimat Rd, Unit 1, Mississauga, Ontario, L5N 5M2, Canada.

Telephone:  
Ontario (289) 328-0651, (877) 538-8078  
Quebec (514) 587-2607, (855) 296-4372

E-mail: [Sales@Tigerpak.ca](mailto:Sales@Tigerpak.ca) [Info@Tigerpak.ca](mailto:Info@Tigerpak.ca)  
Website: [www.tigerpak.ca](http://www.tigerpak.ca)

